

Introduction

The ICL7106 and ICL7107 are the first ICs to contain all the active circuitry for a 3¹/₂ digit panel meter on a single chip. The ICL7106 is designed to interface with a liquid crystal display (LCD) while the ICL7107 is intended for light-emitting diode (LED) displays. In addition to a precision dual slope converter, both circuits contain BCD to seven segment decoders, display drivers, a clock and a reference. To build a high performance panel meter (with auto zero and auto

polarity features) it is only necessary to add display, 4 resistors, 4 capacitors, and an input filter if required (Figures 1 and 2).

The ICL7136 is an ultra low power version of the ICL7106. Except for the passive component values as shown in Figure 3 and Table 1, all references in this document to the ICL7106 also apply to the ICL7136.

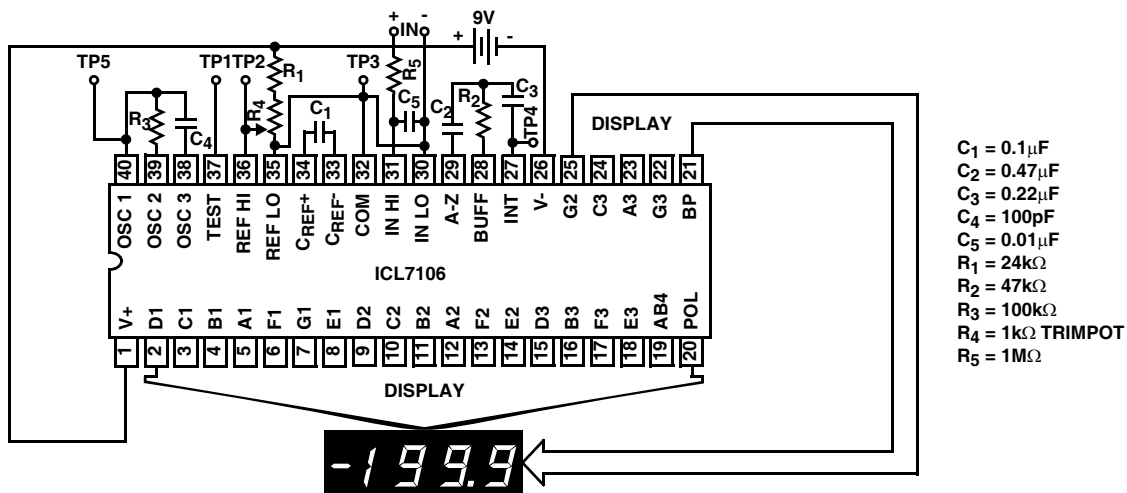

FIGURE 1. LCD DIGITAL PANEL METER USING ICL7106

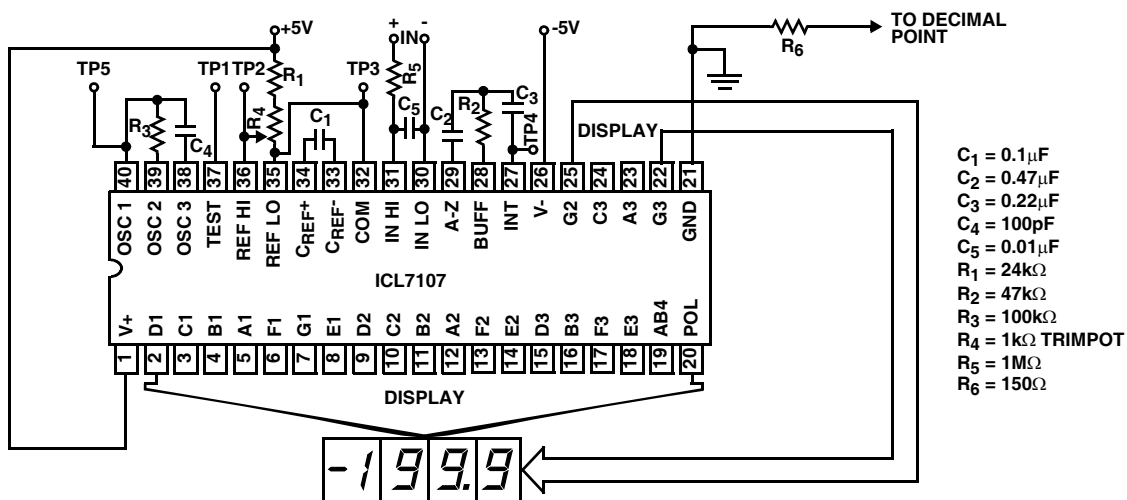

FIGURE 2. LED DIGITAL PANEL METER USING ICL7107

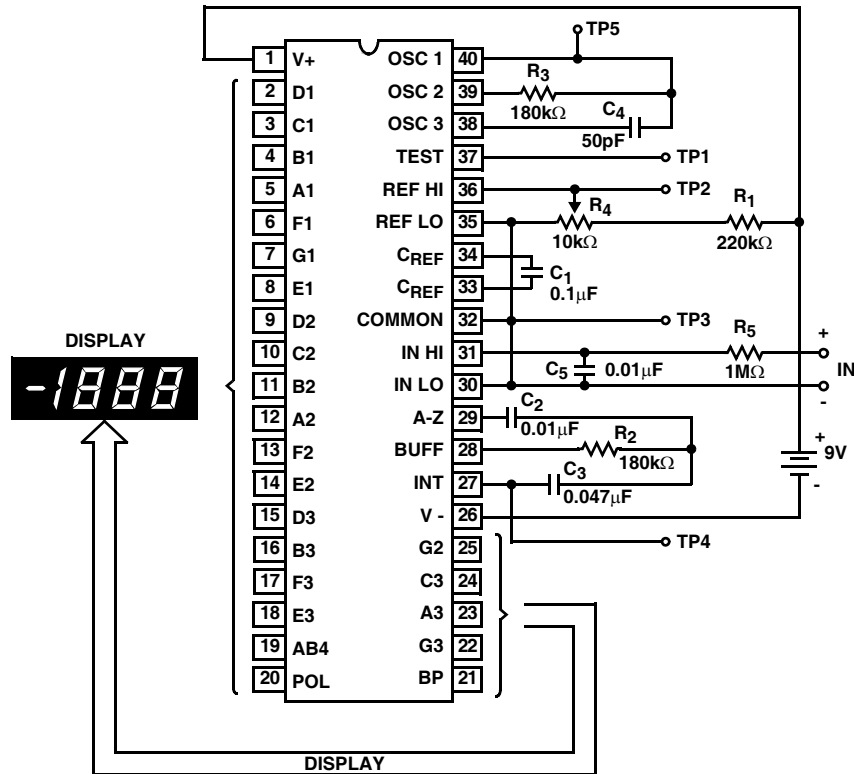

FIGURE 3. LCD DIGITAL PANEL METER USING ICL7136

The Evaluation Kits

After purchasing a sample of the ICL7106 or the ICL7107, the majority of users will want to build a simple voltmeter. The parts can then be evaluated against the data sheet specifications, and tried out in the intended application. However, locating and purchasing even the small number of additional components required, then wiring a breadboard, can often cause delays of days or sometimes weeks. To avoid this problem and facilitate evaluation of these unique circuits, Intersil offers a kit which contains all the necessary components to build a 3¹/₂ digit panel meter. With the help of this kit, an engineer or technician can have the system “up and running” in about half an hour.

Two kits are offered, ICL7106EV/KIT and ICL7107EV/KIT. Both contain the appropriate IC, a circuit board, a display (LCD for ICL7106EV/KIT, LEDs for ICL7107EV/KIT), passive components, and miscellaneous hardware.

Assembly Instructions

The circuit board layouts and assembly drawings for both kits are given in Figures 10, 11. The boards are single-sided to minimize cost and simplify assembly. Jumpers are used to allow maximum flexibility. For example, provision has been made for connecting an external clock (Test Point #5). Provision has also been made for separating REF Lo from COMMON when using an external reference zener. In a production instrument, the board area could be reduced

dramatically. Aside from the display, all the components can easily be placed in less than 4 square inches of board space.

Molex™ pins are used to provide a low cost IC socket; one circuit board can thus be used to evaluate several ICs. (Strips of 20 pins should be soldered onto the PC boards; the top of the strip holding the pins together can then be broken off by bending it back and forth using needle-nose pliers.) Solder terminals are provided for the five test points, and for the ±5V input on the ICL7107 kit.

Full Scale Reading - 200mV or 2.000V?

The component values supplied with the kit are those specified in the schematics of Figure 1 or Figure 2. They have been optimized for 200mV full scale reading. The complete absence of last digit jitter on this range illustrates the exceptional noise performance of the ICL7106 and ICL7107. In fact, the noise level (not exceeded 95% of time) is about 15μV, a factor of 10 less than some competitive one chip panel meters.

To modify the sensitivity for 2.000V full scale, the integrator time constant and the reference should be changed by substituting the component values given in Table 1. The auto-zero capacitor (C₂) should also be changed. These additional components are not supplied in the kits. In addition, the decimal point jumper should be changed so the display reads 2.000.

TABLE 1. COMPONENT VALUES FOR FULL SCALE OPTIONS

COMPONENT	200.0mV FULL SCALE	2.000V FULL SCALE
C ₂ (Mylar™)	0.47μF	0.047μF
R ₁	24kΩ	1.5kΩ (Note)
R ₂	47kΩ	470kΩ
C2	0.1μF	0.022μF
R1	220kΩ	150kΩ
R2	180kΩ	1.8MΩ
R4	10kΩ	100kΩ

NOTE: Changing R₁ to 1.5kΩ will reduce the battery life of the ICL7106 kit. As an alternative, the potentiometer can be changed to 25kΩ.

Liquid Crystal Display (ICL7106)

Liquid crystal displays are generally driven by applying a symmetrical square wave to the Back Plane (BP). To turn on a segment, a waveform 180° out of phase with BP (but of equal amplitude) is applied to that segment. Note that excessive DC voltages (>50mV) will permanently damage the display if applied for more than a few minutes. The ICL7106 generates the segment drive waveform internally, but the user should generate the decimal point front plane drive by inverting the BP (pin 21) output (Note 1). In applications where the decimal point remains fixed, a simple MOS inverter can be used (Figure 4). For instruments where the decimal point must be shifted, a quad exclusive OR gate is recommended (Figure 5). Note that in both instances, TEST (pin 37, TP1) is used as V- for the inverters. This pin is capable of sinking about 1mA, and is approximately 5V below V+. The BP output (pin 21) oscillates between V+ and TEST.

NOTE:

1. In some displays, a satisfactory decimal point can be achieved by tying the decimal front plan to COMMON (pin 32). This pin is internally regulated at about 2.8V below V+. Prolonged use of this technique, however, may permanently burn-in the decimal, because COMMON is not exactly midway between BP high and BP lo.

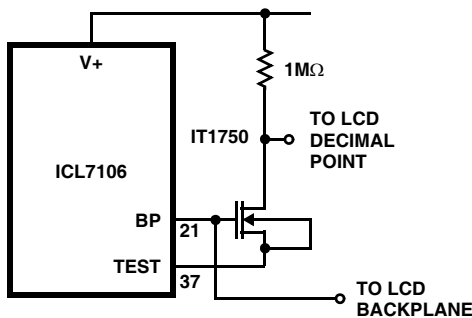

FIGURE 4. SIMPLE INVERTER FOR FIXED DECIMAL POINT

Before soldering the display onto the circuit board, make sure that it is inserted correctly. Many LCD packages do not have pin #1 marked, but the segments of an unenergized display can be seen by viewing with reflected light.

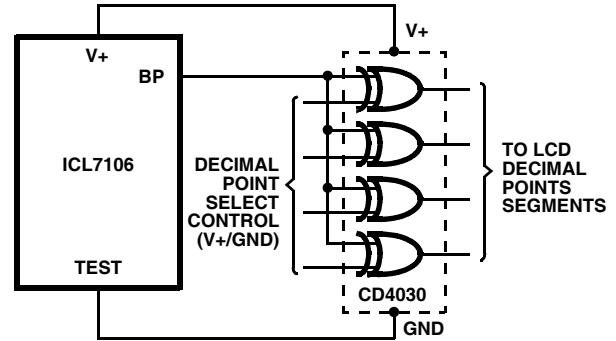

FIGURE 5. EXCLUSIVE 'OR' GATE FOR DECIMAL POINT DRIVE

Light Emitting Diode Display (ICL7107)

The ICL7107 pull-down FETs will sink about 8mA per segment. Using standard common anode 0.3in or 0.43in red LEDs, this drive level produces a bright display suitable for almost any indoor application. However, additional brightness can be achieved through the use of Hewlett Packard high-efficiency LEDs. Note that the display contrast can be increased substantially by using a red filter. Reference [4] discusses filter techniques and lists manufacturers of suitable materials.

A fixed decimal point can be turned on by tying the appropriate cathode to ground through a 150Ω resistor. The circuit boards supplied with the kit will accommodate either HP 0.3in displays or the popular MAN 3700 types. The difference between the two is that the HP has the decimal point cathode on pin 6, whereas the MAN 3700 uses pin 9. Due to the limited space on the circuit board, not all decimal points are brought to jumper pads; it may be necessary to wire directly from the 150Ω resistor to the display. For multiple range instruments, a 7400 series CMOS quad gate or buffer should be used. The majority of them are capable of sinking about 8mA.

Capacitors

The integration capacitor should be a low dielectric-loss type. Long term stability and temperature coefficient are unimportant since the dual slope technique cancels the effect of these variations. Polypropylene capacitors have been found to work well; they have low dielectric loss characteristics and are inexpensive. However, that is not to say that they are the only suitable types. Mylar capacitors are satisfactory for C₁ (reference) and C₂ (auto-zero).

For a more detailed discussion of recommended capacitor types, see page three of Reference [2].

The Clock

A simple RC oscillator is used in the kit. It runs at about 48kHz and is divided by 4 prior to being used as the system clock (Figure 6). The internal clock period is thus 83.3 μ s, and the signal integration period (1000 clock pulses) is 83.3ms. This gives a measurement frequency of 3 readings per second since each conversion sequence requires 4000 clock pulses. Setting the clock oscillator at precisely 48kHz will result in optimum line frequency (60Hz) noise rejection, since the integration period is an integral number of line frequency period. [2] Countries with 50Hz line frequencies should set the clock at 50kHz.

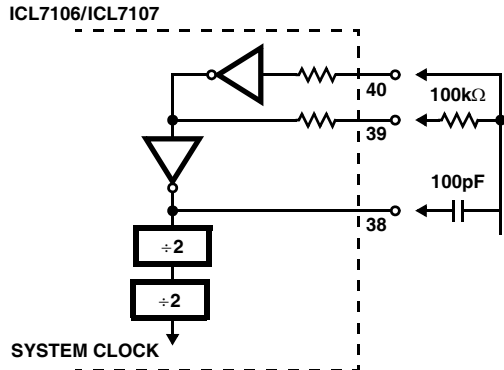

FIGURE 6. ICL7106/ICL7107 INTERNAL OSCILLATOR CLOCK

An external clock can also be used. In the ICL7106, the internal logic is referenced to TEST. External clock waveforms should therefore swing between TEST and V+ (Figure 7A). In the ICL7107, the internal logic is referenced to GND so any generator whose output swings from ground to +5V will work well (Figure 7B).

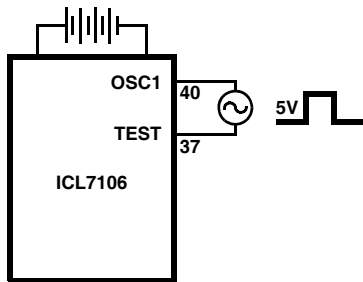

FIGURE 7A. ICL7106

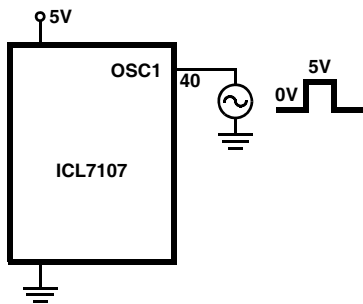

FIGURE 7B. ICL7107

FIGURE 7. EXTERNAL CLOCK OPTIONS

The Reference

For 200.0mV full scale, the voltage applied between REF Hi and REF Lo should be set at 100.0mV. For 2.000V full scale, set the reference voltage at 1.000V. The reference inputs are floating, and the only restriction on the applied voltage is that it should lie in the range V- to V+.

The voltage between V+ and COMMON is internally regulated at about 2.8V. This reference is adequate for many applications and is used in the evaluation kits. It has a typical temperature coefficient of 100ppm/ $^{\circ}$ C.

The limitations of the on-chip reference should also be recognized, however. With the ICL7107, the internal heating which results from the LED drivers can cause some degradation in performance. Due to its high thermal resistance, plastic parts are poorer in this respect than ceramic. The user is cautioned against extrapolating from the performance of the kit, which is supplied with a ceramic ICL7107, to a system using the plastic part. The combination of reference TC, internal chip dissipation, and package thermal resistance can increase noise near fullscale from 25 μ V to 80 μ V_{P-P}.

The linearity in going from a high dissipation count such as 1000 (19 segments on) to a low dissipation count such as 1111 (8 segments on) can also suffer by a count or more. Devices with a positive TC reference may require several counts to pull out of an overload condition. This is because overload is a low dissipation mode, with the three least significant digits blanked. Similarly, units with a negative TC may cycle between overload and a nonoverload count as the die alternately heats and cools. These problems are of course eliminated if an external reference is used.

The ICL7106, with its negligible dissipation, suffers from none of these problems. In either case, an external reference can easily be added as shown in Figures 8A or 8B.

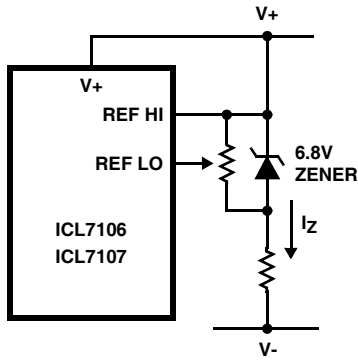

FIGURE 8A.

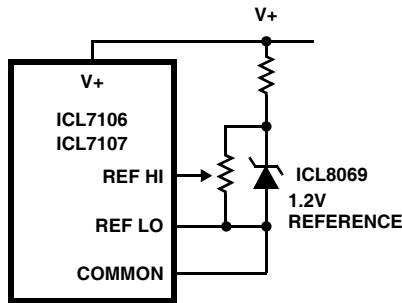

FIGURE 8B.

FIGURE 8. USING AN EXTERNAL REFERENCE

Power Supplies

The ICL7106 kit is intended to be operated from a 9V dry cell. INPUT Lo is shorted to COMMON, causing V+ to sit 2.8V positive with respect to INPUT Lo, and V- 6.2V negative with respect to INPUT Lo.

The ICL7107 kit should be operated from $\pm 5V$. Noisy supplies should be bypassed with $6.8\mu F$ capacitors to ground at the point where the supplies enter the board. INPUT Lo has an effective common mode range with respect to GND of a couple of volts.

The precise value is determined by the point at which the integrator output ramps within $\sim 0.3V$ of one or other of the supply rails. This is governed by the integrator time constant, the magnitude and polarity of the input, the common mode voltage, and the clock frequency: for further details, consult the data sheet. Where the voltage being measured is floating with respect to the supplies, INPUT Lo should be tied to some voltage within the common mode range such as GROUND or COMMON. If a $-5V$ supply is unavailable, suitable negative rail can be generated locally using the circuit shown in Figure 9.

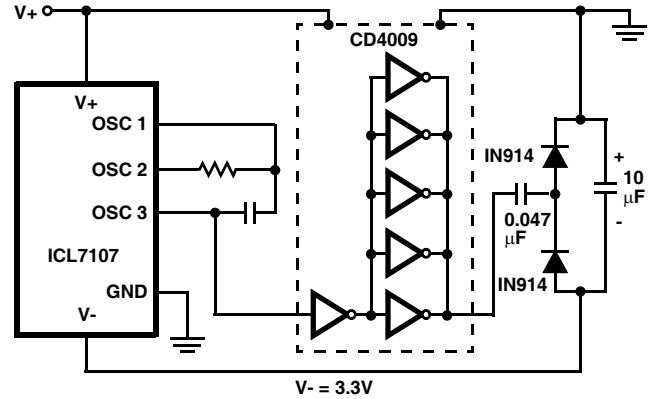

FIGURE 9. GENERATING NEGATIVE SUPPLY FROM +5V

Input Filters

One of the attractive features of the ICL7106 and ICL7107 is the extremely low input leakage current, typically $1pA$ at $25^{\circ}C$. This minimizes the errors caused by high impedance passive filters on the input. For example, the simple RC ($1M\Omega/0.01\mu F$) combination used in the evaluation kits introduces a negligible $1\mu V$ error.

Preliminary Tests

Auto Zero

With power on and the inputs shorted, the display should read zero. The negative sign should be displayed about 50% of the time, an indication of the effectiveness of the auto-zero system used in the ICL7106 and ICL7107. Note that some competitive circuits flash negative on every alternate conversion for inputs near zero. While this may look good to the uninitiated, it is not a true auto zero system!

Over-Range

Inputs greater than full scale will cause suppression of the three least significant digits; i.e., only 1 or -1 will be displayed.

Polarity

The absence of a polarity signal indicates a positive reading. A negative reading is indicated by a negative sign.

Further evaluation should be performed with the help of a precision DC voltage calibrator such as Fluke Model 343A. Alternatively a high quality $4\frac{1}{2}$ digit DVM can be used, provided its performance has been measured against that of a reliable standard.

DPM Components: Sources of Supply

It has already been shown that the ICL7106 and ICL7107 require an absolute minimum of additional components. The only critical ones are the display and the integration capacitor.

The following list of possible suppliers is intended to be of assistance in putting a converter design into production. It should not be interpreted as a comprehensive list of suppliers, nor does it constitute an endorsement by Intersil.

Liquid Crystal Displays

1. LXD Inc., Cleveland, Ohio
2. Hamlin Inc., Lake Mills, Wisconsin
3. IEE Inc., Van Nuys, California
4. Shelley Associates, Irvine, California
5. Crystaloid Electronics, Stow, Ohio

LED Displays (Common Anode)

1. Hewlett Packard Components, Palo Alto, California
2. Itac Inc., Santa Clara, California
3. Litronix Inc., Cupertino, California
4. Monsanto Inc., Palo Alto, California

Polypropylene Capacitors

1. Plessey Capacitors, West Lake Village, California
2. IMB Electronic Products, Santa Fe Springs, California
3. Elcap Components, Santa Ana, California
TRW Capacitors, Ogallala, Nebraska

CAUTION: Potential trouble areas when constructing the evaluation kits:

1. Certain LCD displays have a protective plastic sheet covering the plastic top. This sheet may be removed after installing the display to maximize display viewing.
2. Solder flux or other impurities on PC board may cause leakage paths between IC pins and board traces reducing performance and should be removed with rubbing alcohol or some other suitable cleaning agent. Displays should be removed when cleaning as damage could result to them.
3. Blue PC board material (PC75) has been treated with a chemical which may cause surface leakage between the input traces. It is suggested that the board be scribed between the input traces and adjacent traces to eliminate this surface leakage.

In order to ensure that unused segments on the LCD displays do not turn on, tie them to the backplane pin (pin 21).

References

- [1] AN016 *Application Note*, Intersil Corporation, "Selecting A/D Converters", Dave Fullagar.
- [2] AN017 *Application Note*, Intersil Corporation, "The Integrating A/D Converter", Lee Evans.
- [3] AN018 *Application Note*, Intersil Corporation, "Do's and Don'ts of Applying A/D Converters", Peter Bradshaw and Skip Osgood.
- [4] Hewlett Packard (Opto Electronics Div.) Application Note 964, "Contrast Enhancement Techniques".
- [5] AN032 *Application Note*, Intersil Corporation, "Understanding the Auto-Zero and Common Mode Performance of the ICL7106/7107/7109 Family", Peter Bradshaw.

All Intersil U.S. products are manufactured, assembled and tested utilizing ISO9000 quality systems. Intersil Corporation's quality certifications can be viewed at www.intersil.com/design/quality

Intersil products are sold by description only. Intersil Corporation reserves the right to make changes in circuit design, software and/or specifications at any time without notice. Accordingly, the reader is cautioned to verify that data sheets are current before placing orders. Information furnished by Intersil is believed to be accurate and reliable. However, no responsibility is assumed by Intersil or its subsidiaries for its use; nor for any infringements of patents or other rights of third parties which may result from its use. No license is granted by implication or otherwise under any patent or patent rights of Intersil or its subsidiaries.

For information regarding Intersil Corporation and its products, see www.intersil.com

5.500 ± .005

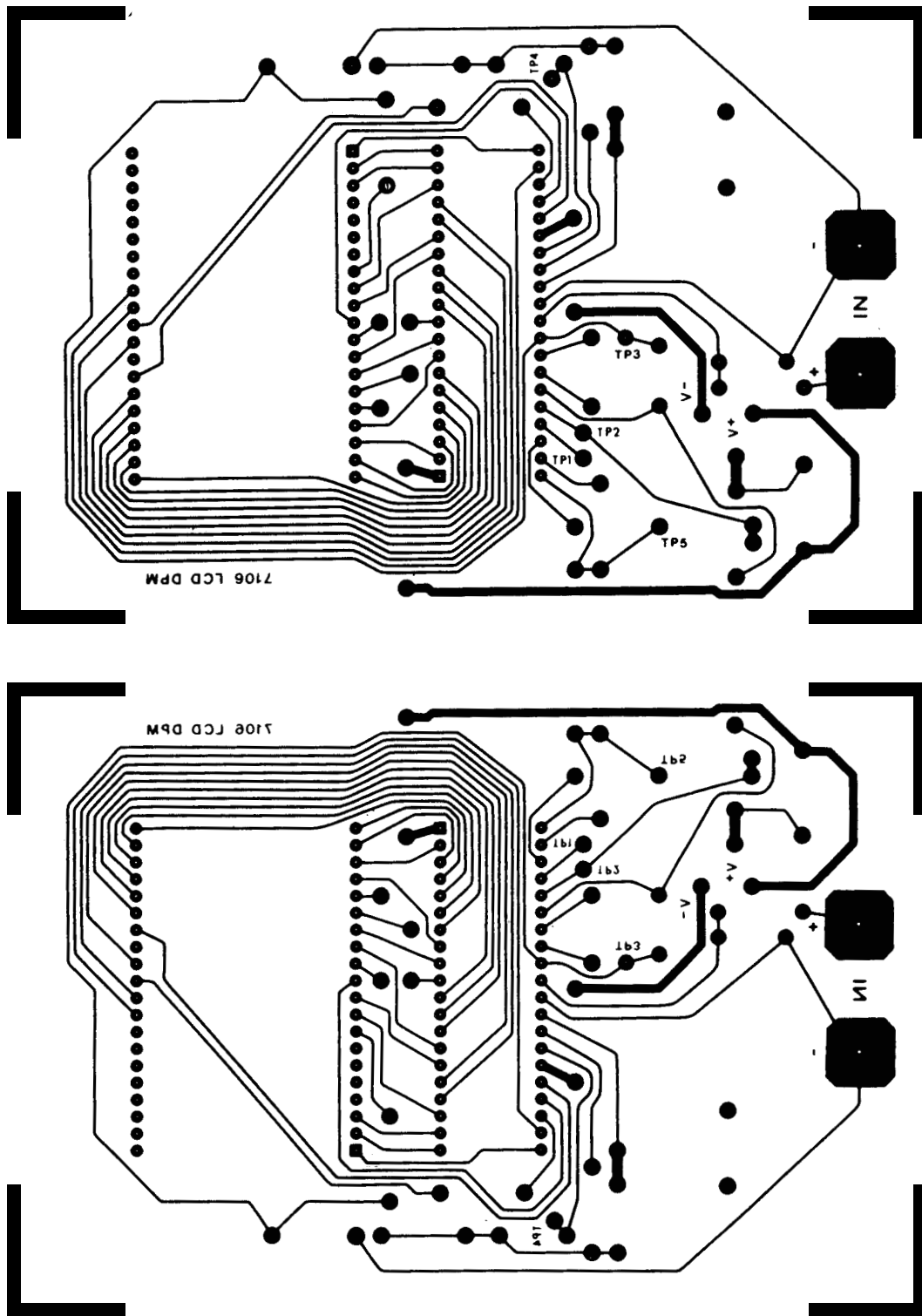

FIGURE 10. ICL7107 PRINTED CIRCUIT BOARD AND COMPONENT PLACEMENT

5.500 ± .005

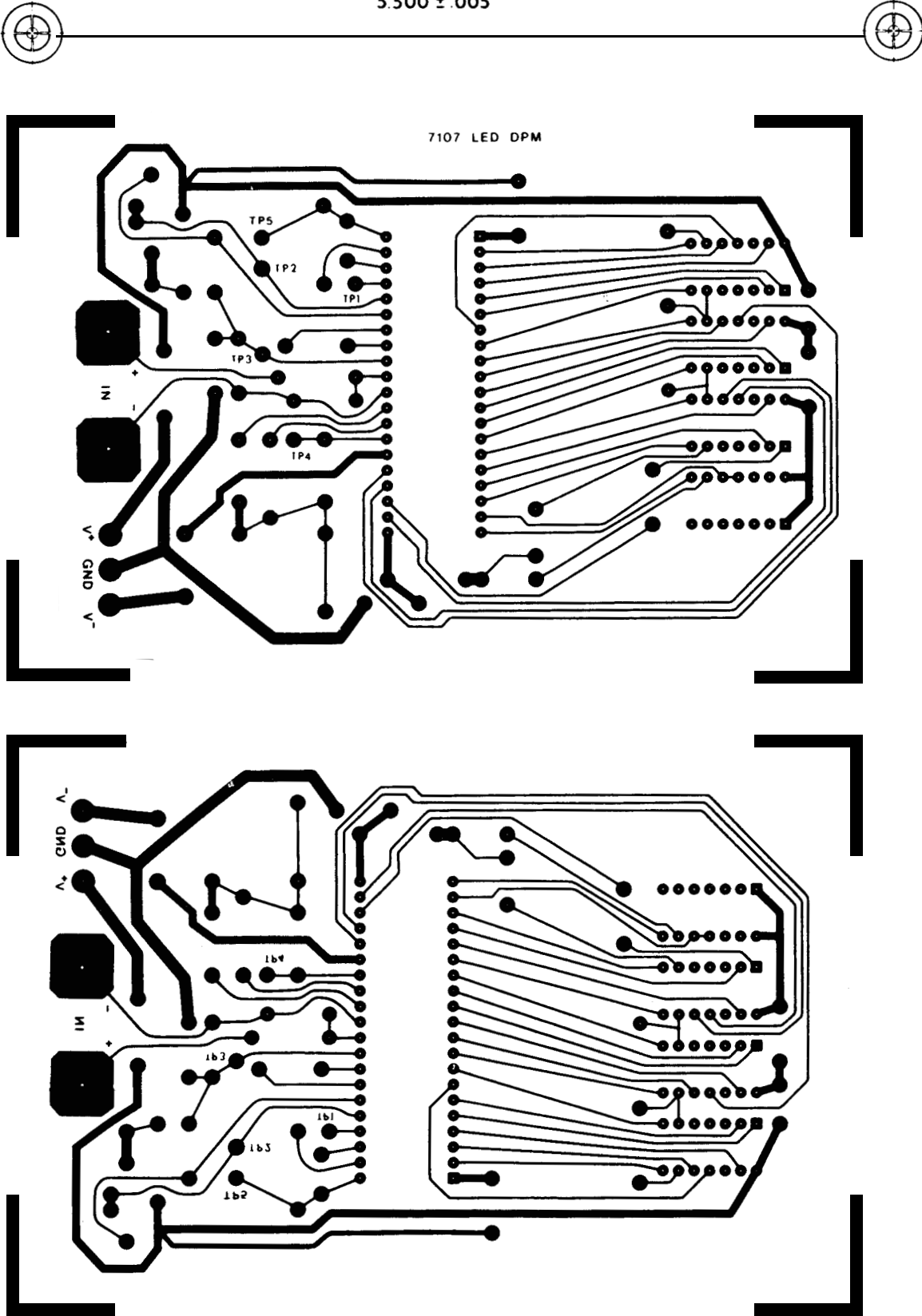

FIGURE 11. ICL7107 PRINTED CIRCUIT BOARD AND COMPONENT PLACEMENT